

# Perimitrax

## Buried Cable Intrusion Detection Sensor



Perimitrax® is a covert perimeter intrusion detection sensor that generates an invisible electromagnetic field around buried sensor cables. If an intruder disturbs the field, an alarm is declared. In the case of a network system, the alarm is instantly communicated over the sensor cables to a PC-based central control system.

Unlike many sensors, Perimitrax uses a large volumetric field to detect moving targets based on their electrical conductivity, size and movement. Unless a target possesses the minimum alarm characteristics, it will not be detected. A person or vehicle crossing through the field is detected while small animals and birds are ignored. Common environmental false alarm sources like foliage, rain, snow and blowing sand are easily filtered out by Perimitrax's advanced adaptive algorithms. This intelligent signal processing provides the highest Probability of Detection (Pd) of any sensor type and an extremely low False and Nuisance Alarm Rate (FAR/NAR).

Because the sensor cables do not change site aesthetics and the detection field is invisible, intruders are unaware of Perimitrax's presence and cannot locate,

avoid or tamper with it. Combined with the sensor's advanced technical capabilities, these inherent features result in the lowest Vulnerability to Defeat (Vd) of any outdoor sensor.

The major benefits of Perimitrax are its superior sensor technology and its ability to tie together a facility's entire security system of outdoor sensors and auxiliary devices. Perimitrax uses its sensor cables to communicate with and supply power to the Sensor Modules and auxiliary sensors. The Perimitrax Central Controller, the Senstar® 100 or the StarNeT 1000 provide central alarm reporting and control. These PC-based systems have a simple map-based, graphical user interface. The thresholds of each Perimitrax zone are easily adjusted from the central console through powerful maintenance software.

Perimitrax provides a high level of user confidence and a rapid return on investment through reduced operating and maintenance costs, increased staff efficiency and reduced losses.

Covert sensor with invisible volumetric detection field

Terrain-following

Continuous field of detection with over 99% Probability of Detection

Superior height response

Adaptive algorithms for dependable all-weather performance

The lowest vulnerability to defeat of any outdoor sensor technology

Power, data and detection on the same cable set reduces installation costs

PC-based network control with remote adjustment of all operating parameters

## PERIMITRAX CABLE SYSTEM

Perimitrax uses ported (“leaky”) coaxial sensor cables to create an invisible electromagnetic detection field. A gap in the transmit cable outer conductor allows electromagnetic energy to escape and be detected by a corresponding parallel receive cable. The cables can be buried in any medium such as soil, sand, clay, concrete or asphalt to form a uniform, covert, volumetric detection field that is terrain-following. The cables are located at the center of a 5 m (16 ft.) strip that is free of all moving metallic objects. They should be at least 3 m (9.8 ft.) from large moving metallic objects such as chain-link fences. The length of each zone can vary from 10 m (33 ft.) to 200 m (656 ft.) and is customized to suit site requirements. The cables are available in two configurations. SC1 has the transmit and receive cables in a single jacket. A single burial trench or slot is required, saving installation time and expense. The resulting detection field is typically 1 m (3.3 ft.) high and 2 m (6.6 ft.) wide. The actual field size depends on the burial depth, the burial medium and the thresholds chosen. For those sites where space is not a problem and a wider field is desired, SC2 cables are used. SC2 has its transmit and receive cables buried separately approximately 2 m (6.6 ft.) apart. This results in a detection field that is typically 1 m (3.3 ft.) high and 3 m (9.8 ft.) wide.

### Buried Coaxial Cable

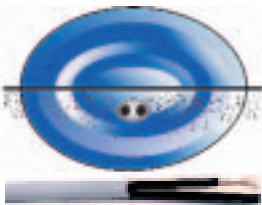

**SC1 - Single Buried Cable Sensor**

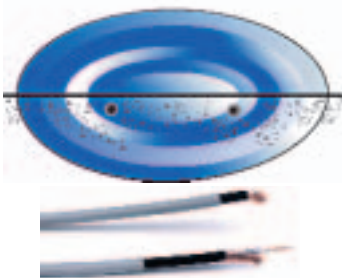

**SC2 - Dual Buried Cable Sensor**

## PERIMITRAX CABLE INSTALLATION

For burial in soil, a trench 30 cm (12 in.) deep by 10 cm (4 in.) wide is prepared. The cable is deployed at a depth of 23 cm (9 in.) and cut to suit the desired zone length. Decouplers and terminators are installed as required. Native soil is used to fill the trench and the original soil covering (e.g. lawn) is restored. For SC2 cables, two trenches up to 2 m (6.6 ft.) apart are needed. For burial in existing asphalt or concrete, a slot 1 cm (3/8 in.) wide and 6 cm (2 in.) deep is prepared using a concrete saw. The cable is inserted at the bottom of the slot and the slots are filled with foam backer rods. Joint sealant is used to seal the sensor cable in the slot. For SC2 cables, two slots 2 m (6.6 ft.) apart are required. For sites where the asphalt or concrete has not yet been installed, the cable(s) can be installed at the standard depth of 23 cm (9 in.). If the concrete is reinforced, contact the factory. Non-sensitive lead-in cable, which is an integral part of the sensor cable, is used to make the necessary connections to the Perimitrax Sensor Module (SM). The SM is installed in either a NEMA 4 weatherproof enclosure or a Telecom-style protective enclosure. Senstar-Stellar provides technical training and on-site support to all new installers.

### Installing Underground Cable

Medium	Buried Depth
- Soil, Gravel, Asphalt or Concrete < 10 cm (4 in.) thick	- 23 cm (9 in.)
- Asphalt or Concrete > 10 cm (4 in.) thick	- 6 cm (2.25 in.) slot
- Reinforced Concrete Any thickness	- contact factory

## PERIMITRAX DETECTION CHARACTERISTICS

After the Perimitrax cables are installed and the site is returned to its original condition, the volumetric detection field is completely invisible and extends both above and below ground. Detection is based on intruder electrical conductivity, size and speed. The Probability of Detection (Pd) for intruders with a mass greater than 34 kg (75 lbs.) is greater than 99%, while intruders less than 10 kg (22 lbs.) are rejected, with a statistical confidence level of 95%. Detection is made for intruder speeds ranging from 2.5 cm/s (1 in./sec.) to 15 m/s (49 ft./sec.). Separate, more sensitive thresholds can be set for running/jumping intruders. Any attempt to tamper with the cables or the processor or its enclosure causes an alarm. Perimitrax is recognized for its very low false/nuisance alarms from vegetation, rain, snow, hail, sandstorms, wind, fog, temperature changes, RFI, EMI, seismic vibration, acoustic and magnetic effects.



## Applications

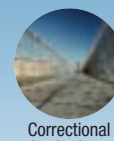
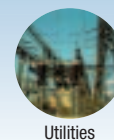
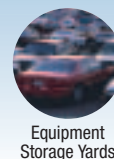
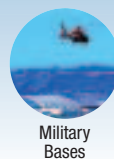

## Configurations

### NETWORK CONFIGURATION FEATURES

- Recommended for 4 or more zones
- Sensor, power and data signals are transmitted on the same cables
- Installation and maintenance cost savings
- SC1 or SC2 cable sets
- Up to 9 processors on a single 48 VDC power supply
- 8 additional inputs per processor for auxiliary sensor alarm and tamper
- 4 relay outputs per processor for controlling auxiliary devices
- Power output for auxiliary devices 12 VDC, 150 mA per processor
- Remote adjustment of all sensor zone thresholds from the central control
- Remote display of the analog output of each zone
- Secure alarm data communications and control
- Lightning protection on all inputs and outputs
- PC central control with the Perimitrax Central Controller, the Senstar 100 or the StarNeT 1000

### PERIMITRAX CENTRAL CONTROLLER MODEL CC100-1

- Commercial PC Computer chassis with Color Monitor, Keyboard and Mouse
- One parallel port for printer output, one serial port to Network Controller, one serial port for mouse
- Maximum Number of Sensor Zones 64 (32 Perimitrax Processors)
- Display of all sensor alarm conditions
- Standard graphical display optional Custom Map display
- Simple menu-driven alarm response functions
- Maintenance software to monitor Sensor Module operation
- Optional pass-through alarm relay inputs/outputs
- Easily expanded to a Senstar 100 system

### SENSTAR 100 & StarNeT 1000

- See Senstar-Stellar product literature

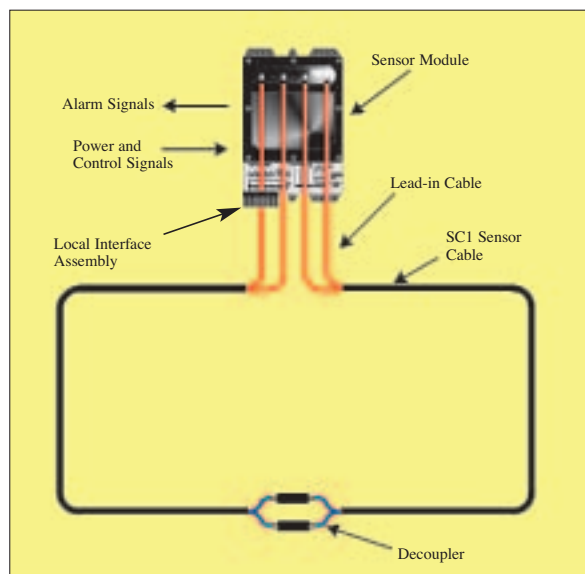
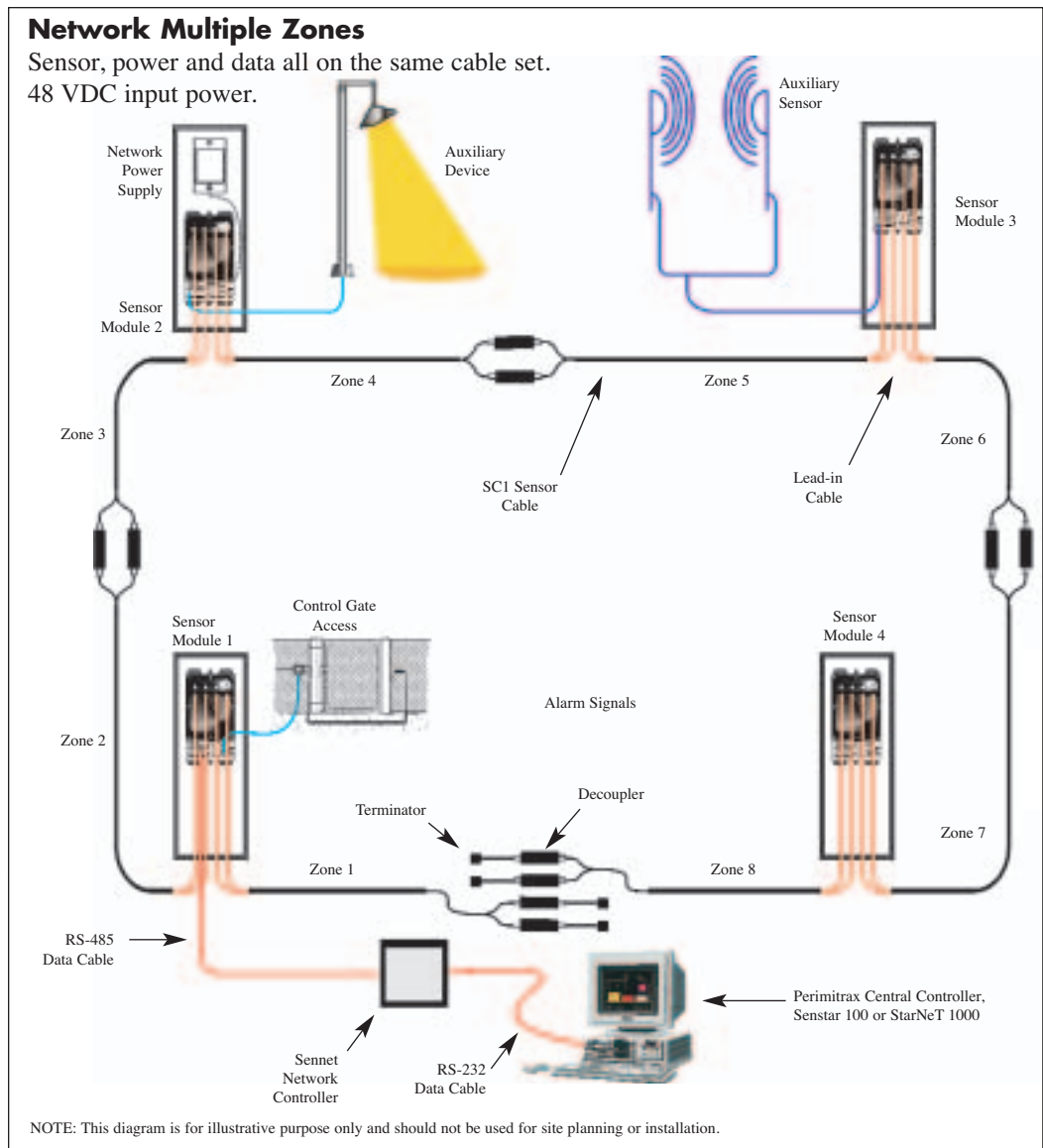

### Standalone Configuration Features

- Recommended for up to 6 zones of protection
- 2 zones to a maximum length of 400 m (1320 ft.) per processor
- 12 VDC input power
- Separate relay outputs for Alarm A, Alarm B, Tamper, Fail
- Setup using the Local Interface Assembly
- Analog outputs for the detection signal in each zone
- SC1 or SC2 cable sets
- All-weather, all-climate operation
- Lightning protection on all inputs and outputs

## SPECIFICATIONS

### SENSOR CABLE

#### Required

- One roll of SC1 or two rolls of SC2 cable

#### Length

- 50, 100, 150 or 200 m (164, 328, 492, 656 ft.) detection length, each cable with 20 m (66 ft.) integral non-sensitive lead-in cable

#### Size

- SC1: 8.5 x 15 mm (0.335 x 0.590 in.)
- SC2: 8.0 mm (0.315 in.) diameter

#### Operational temperature

- -40°C to +70°C (-40°F to 158°F)

#### Storage temperature

- -50°C to +85°C (-58°F to 185°F)

#### Reel diameter

- SC1: 508 mm (20 in.) dia. x 330 mm (13 in.) wide
- SC2: 406 mm (16 in.) dia. x 330 mm (13 in.) wide

#### Weights

- SC1: 38.6 kg (85 lbs.) max.
- SC2: 25 kg (53.5 lbs.) max.

### SENSOR MODULE SM100-1 (SM)

#### Number of sensor zones per SM - 2

#### Zone length

- Min. 10 m (33 ft.)
- Max. 200 m (656 ft.)

#### Tamper alarm

- By enclosure tamper switch

#### Self test function

- Internal, activated at the CC or at the SM

#### Calibration outputs

- 2 analog outputs for voltmeter or chart recorder

#### Detection threshold

- Adjustable for each zone

#### Velocity response

- 2.5 cm/s (1 in./sec.) to 15 m/s (49 ft./sec.) adjustable

#### Probability of detection

- >99% for walking intruder with weight >34 kg (75 lbs.)

#### Frequency

- 40.675 MHz zone A,
- 40.685 MHz zone B

#### Operating temperature

- -40°C to +70°C (-40°F to +158°F)

#### Operating humidity

- 0% to 95% RHNC

#### Housing

- *Castings* - cast aluminum
- *Size* - 360 L x 230 W x 100 mm H (14 L x 9 W x 4 in. H)
- *Weight* - 4.5 kg (10 lbs.)

#### Power consumption

- 12 VDC @ 500 mA or
- 48 VDC @ 175 mA

#### Regulatory approvals

- *Canada* - IC, CAN-1454-102-239
- *U.S.A.* - FCC, IS-T-BCIDS001
- *Europe* - CEPT SRD 1d GB

#### Standalone model features

- Alarm Relay outputs - 4 relay outputs
- 24 VDC max. 350 mA DC max.

#### Network model features

- *Inputs* - 8 auxiliary relay inputs (supervised) 2.2 kΩ

- *Outputs* - 4 auxiliary relay outputs

- 24 VDC max 350 mA DC max.

- *Power output* (for ext. Sensors)

- 12 VDC @ 150 mA max.

- *Controls* - 8 position DIP switch for network address selection and unit configuration.

- Data Port - RS-485

### SENSOR MODULE SM100-2 (SM)

Information is the same as above, except

#### Frequency

- 40.665 MHz zone A
- 40.695 MHz zone B

### OPTIONS

#### Protective telecom enclosure

- *Size* - 254 x 254 x 910 mm (10 x 10 x 36 in.)
- *Color* - light green enamel over steel
- *Protection* - IP33

#### Outdoor enclosure

- *Size* - 510 x 510 x 150 mm (20 x 20 x 6 in.)
- *Color* - gray enamel over steel (stainless steel optional)
- *Protection* - IP66/NEMA 4
- *Weight* - 12.3 kg (27 lbs.)

#### Standalone power supply (FPM - 12)

- *Power input* - 115/230 VAC, 60/50 Hz, 75W
- *Power output* - 12 VDC, 4A max.
- Max. Number of SMs - 1

#### Network power supply (FPM-48)

- *Power input* - 115/230 VAC, 60/50 Hz, 200 W
- *Power output* - 48 VDC, 3A max.
- Max. number of SMs - 9 SMs or 2,800 m (3,062 yds.) of sensor cable

### PERIMITRAX CENTRAL CONTROLLER CC100-1 (CC)

#### Number of zones

- Max 32 SMs (64 sensor zones, 256 auxiliary inputs, 128 dry relay outputs)
- Easily upgraded to the Senstar 100

#### Interfaces

- 1-parallel port for printer
- 1-serial port to Network Controller
- 1-serial port for mouse

#### Power

- 115/230 VAC 60/50 Hz

#### Consumption

- 300 W typical (dependent on configuration)

#### Operating temperature

- 10°C to 35°C (50°F to 95°F) commercial
- 10°C to 50°C (50°F to 122°F) industrial

#### Operating humidity

- 8 to 80% RHNC commercial
- 8 to 90% RHNC industrial

#### Size

- Dependent on configuration

#### Weight

- Commercial computer chassis 11.5 kg (25 lbs.) Typ.
- 14 in. color monitor-12 kg (26.5 lbs.) Typ.

### SENNET NETWORK CONTROLLER (NC)

#### Quantity

- One per Network

#### Host

- CC100-1 supports one NC
- Senstar 100 supports up to 36 NC's

#### Host Interface

- RS-232 or RS-422 serial data link up to 19200 baud

#### Controls

- DIP switch for setting host baud rate
- Reset switch
- Diagnostic test switch

#### LED Indicators

- Network transmit and receive
- Host transmit and receive
- Self-test status

#### Operating temperature

- 0°C to 55°C (32°F to 131°F)

#### Operating humidity

- 5 to 95% RHNC

#### Standard Enclosure (indoor)

- *Size* - 400 H x 375 W x 120 mm D (15 H x 14 W x 4 in. D) indoor enclosure
- *Weight* - 9 kg (20 lbs.) w/AC power option, w/o battery
- *Enclosure Option*
- IP66/NEMA 4 rated outdoor enclosure

\* Specifications subject to change without prior notice.



ISO 9001:2000  
CGSB Registered  
Certificate 95711

**INTERNATIONAL**  
Senstar-Stellar Corp.  
119 John Cavanaugh Drive  
Carp, ON K0A 1L0  
Canada  
Tel: (613) 839-5572  
Fax: (613) 839-5830  
info@senstarstellar.com

**UNITED STATES**  
Senstar-Stellar Inc.  
43184 Osgood Road  
Fremont, CA 94539  
Tel: (510) 440-1000  
Fax: (510) 440-8686  
1-800-676-3300 • West Coast (HQ)  
usinfo@senstarstellar.com

**UNITED KINGDOM**  
Senstar-Stellar Limited  
Orchard House  
Evesham Road  
Broadway  
Worcs., U.K. WR12 7HU  
Tel: + 44 (1386) 834433  
Fax: + 44 (1386) 834477  
senstaruk@senstarstellar.com

**LATIN AMERICA**  
Senstar-Stellar Latin America,  
Pradera No.214  
Col. Pradera  
Cuernavaca, Morelos  
62170, Mexico  
Tel: + 52 (777) 313 0288  
Fax: + 52 (777) 317 0364  
info@senstarstellar.com.mx

**EUROPE**  
Senstar GmbH  
Riedheimer Str. 8  
88677 Markdorf Germany  
Tel: + 49 7544-95910  
Fax: + 49 7544-959129  
info@senstar.de



Senstar-Stellar is  
represented by dealers  
in over 75 countries.